



Cratex Manufacturing Co., Inc.
 328 Encinitas Blvd., Suite 200
 Encinitas, California 92024
 Phone: (760) 942-2877 FAX: (760) 942-4513
 Phone: (800) 800-4077 FAX: (800)788-0463

GRIT TEXTURES

Each Cratex size and shape is made in four standard Grit Textures or compositions which differ in accordance with the mesh size of the abrasive grain used.

[C] COARSE (Green) [M] MEDIUM (Dark Brown) [F] FINE (Reddish Brown) [XF] EXTRA FINE (Grey Green)

CRATEX STANDARD BOND

The Cratex bond common to each of the four Grit Textures is made with premium grade oil-resistant chemical rubber. In contrast to conventional grinding wheels the Cratex bond has unique cushioned action...cuts freely, smoothly and softly without gouging or digging into the work surface. It resists clogging or smearing, and is ideal for a broad range of applications where metallic or non-metallic surfaces must be smoothed and polished without loss of dimensional tolerances or control.

CRATEX HARD BOND

The Cratex Hard Bond increases the cutting action when compared to the Cratex standard bond and is designed for use only in specialized applications. The Hard Bond removes burrs on hard metals like stainless steel and can also be used for light grinding on applications where light metal removal is essential. All Cratex Flexible Abrasive Finishers, in each of the four grit textures are available in Hard Bond. Hard Bond is not available in Kits and minimum quantities are required.

CRATEX ABRASIVE TYPE

The abrasive type used in Cratex Rubberized Abrasives is premium-quality Silicon Carbide that has been washed, dried and treated to remove impurities and then carefully screened to U.S. Department of Commerce standards for size. Although silicon carbide is more expensive than other abrasive materials, it is used because it has a high level of purity and has been found to be best for the broadest range of light deburring, smoothing, cleaning and polishing applications on ferrous and non-ferrous alloys as well as many non-metallics, such as glass.

SHAPES AND SIZES

The Cratex Wheels, Points, Cones, Blocks and Sticks listed in this Catalog are all available as standard products. The occasional need for non-catalog shapes or compositions can usually be solved by adapting or modifying standard shapes and compositions to meet special requirements. Several wheels can be mounted in series for added width. The abrasive action of the wheels can be softened by using lower operating speeds and lighter work pressures. Cratex Rubber Bonded Abrasives can also be dressed or shaped to special contours using conventional abrasive wheel dressing tools and methods. Contact a Customer Service Representative for further information.

QUALITY CONTROL

All Cratex Rubberized Abrasives are made and safety inspected to the requirements of American National Standards Institute (ANSI) publication, B7.1 Safety requirements for the use, care and protection of abrasive wheels. This publication should be made available to all operators of Cratex products. Copies of this publication are available from:

Grinding Wheel Institute
 30200 Detroit Road
 Cleveland, Ohio 44145

or

American National Standards Institute
 1430 Broadway
 New York, New York 10018

WARRANTY AND RETURNS POLICIES

If any Cratex item does not perform as promised it is returnable for full credit or exchange.

Return of products ordered in error will be subject to a restocking charge. Cratex will accept the return of large quantities whenever possible. Special orders may not be returned.

All returns must be accompanied by a Returned Goods Authorization Number which can only be obtained from the Cratex Customer Service Department.

WHEN ORDERING

Specify the part number and grit texture. (C) Coarse, (M) Medium, (F) Fine, (XF) Extra Fine. For Example: 54-C. Certain products are sold in units of 1 and others in boxes of 100. Refer to the Cratex Industrial Price List to verify the correct unit when ordering.

Hard Bond — Specify the part number, grit texture and bond. Example: 54-C HB.

BASIC APPLICATIONS

LIGHT DEBURRING and smoothing to relieve stress concentrations and to remove visible and microscopic burrs without impacting surrounding areas.

SMOOTHING and polishing to improve wearing qualities and to reduce the dangers of progressive fracture and fatigue failure.

CLEANING and polishing to remove undesirable surface deposits.

POLISHING and smoothing to improve performance, appearance, cleanliness and to lessen the dangers of surface contamination.

TYPICAL APPLICATIONS

INCLUDE:

Breaking edges, radiusing and polishing out high spots, removing rust, cleaning threads, smoothing the edges of punched or sheared metal, deflashing, smoothing and polishing molds, dies and other production tools, sharpening and honing of cutting dies, blades and edged tools, removing corrosion, excess solder, heat marks, cleaning and polishing contact points, jacks and electrodes, removing tool marks, scratches, light burrs, and fins, blending in welded seams after rough grinding, engine turning, damaskeening, polishing engine ports, shafts, turbine blades, smoothing glass edges, jewelry finishing, gem stone sanding and many others.

Cratex Rubber-bonded Abrasives are used in a widely diversified list of industries, on production and assembly lines, in finishing operations, in tool and machine shops, in the production of basic tools, instruments, component parts and for maintenance and repairs.

CRATEX
Small Wheels
(actual size)



Size No. 2

CRATEX SMALL WHEELS —
TAPERED EDGE

Cratex Shaped Wheels have a tapered edge which makes them exceptionally versatile for fine work on small and delicate parts...ideal for polishing, cleaning out and finishing decorative and intricate designs.

Dimensions in inches

Diameter	Thickness	Arbor Hole	Part No.
3/8	3/32	1/16	1
5/8	3/32	1/16	2
1	1/8	1/16	5

CRATEX SMALL WHEELS —
STRAIGHT EDGE

Cratex Small Straight Wheels can be mounted on conventional portable motor tools and used on a broad list of deburring, smoothing and polishing applications. They can be used on countless operations requiring absolute control of metal removal such as in micro-deburring, relieving stress concentration areas and polishing away fatigue lines, scratches and other surface defects. Ideal for work on dies, molds, instruments, control mechanisms, electronic parts, jewelry, aerospace components, plastic articles, light castings, models, and super sensitive scientific devices.

Dimensions in inches

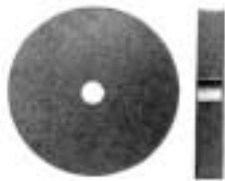

Size No. 74

Diameter	Thickness	Arbor Hole	Part No.
5/8	3/32	1/16	53
	1/8	1/16	54
	1/4	1/16	59
7/8	1/8	1/16	74
	3/16	1/16	76
	1/4	1/16	79
	1/8	1/8	74-2
	3/16	1/8	76-2
1	1/4	1/8	79-2
	3/32	1/16	83
	1/8	1/16	80
	3/16	1/16	86
	1/4	1/16	88
	3/32	1/8	83-2
	1/8	1/8	80-2
3/16	1/8	86-2	
1/4	1/8	88-2	

- The #2 after the above Part No. denotes 1/8" arbor hole.
- When a variety of Small Wheels in quantities of less than 100 is desired, see Cratex Kits and Assortments.
- Maximum Safe Speed 25,000 Revolutions Per Minute. Best results are usually obtained at 30% to 80% of Maximum Safe Speed. Use a light work pressure.

CRATEX Small Wheel Mandrels

Diameter in inches

Part No.	Shank	For Hole
2	3/32	1/16
3	1/8	1/16
5	1/8	1/8
8	1/4	1/8

- Maximum safe Speed 25,000 Revolutions Per Minute with 1/2" overhand or less (exposed mandrel length). For each additional 1/4" of overhand the Maximum Safe Speed is decreased by at least 20%.

(1/2 actual size)



CRATEX POINTS (actual size)

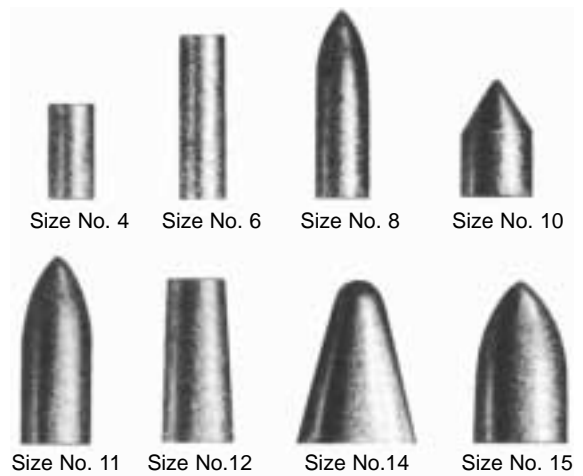

CRATEX POINTS

Cratex Shaped Points are made in both cylinder and bullet shapes...for smoothing and polishing hard to reach surfaces...grooves, ball corners, holes, clasps, spirals, flutes, and edges. They are widely used for polishing molds, dies, patterns and light castings; for cleaning contact points, solder spots and for relieving stress, micro-deburring, and damaskeening.

Dimensions in inches

Shape	Length	Diameter	Arbor Hole	Part No.
Cylinder	1/2	1/4	1/16	4
Cylinder	7/8	1/4	1/16	6
Bullet	1	9/32	1/16	8
Bullet	5/8	3/8	1/16	10
Bullet	1	3/8	1/8	11
Tapered	7/8	3/8 to 5/16	1/8	12
Tapered	7/8	5/8 to 1/8	1/8	14
Bullet	7/8	1/2	1/8	15

- When a variety of Small Wheels in quantities of less than 100 is desired, see Cratex Kits and Assortments.
- Maximum Safe Speed 25,000 Revolutions Per Minute. Best results are usually obtained at 30% to 80% of Maximum Safe Speed. Use a light work pressure.
- To order: Specify Part No. and Grit Texture, C,M,F or XF. Example: 11-M.

CRATEX Point Mandrels

Diameter in inches

Part No.	Shank	For Hole	For Point Nos.
1	3/32	1/16	4,6,8,10
4	1/8	1/16	4,6,8,10
6	1/8	1/8	11,12,14,15
9	1/4	1/8	11,12,14,15

- Mandrels No.1 and No.4 have a No. 3-48 thread and a hex nut flange.
- Mandrel No.6 has a No. 5-40 thread and a hex nut flange.
- Mandrel No.9 has a No.5 screw thread, and a fixed shoulder flange.
- Maximum Safe Speed 25,000 Revolutions Per Minute with 1/2" overhand or less (exposed mandrel length). For each additional 1/4" of overhand the Maximum Safe Speed is decreased by at least 20%.

(1/2 actual size)

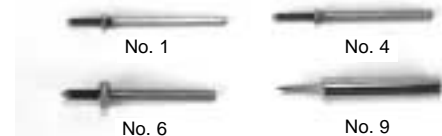

CRATEX CONES (1/2 actual size)

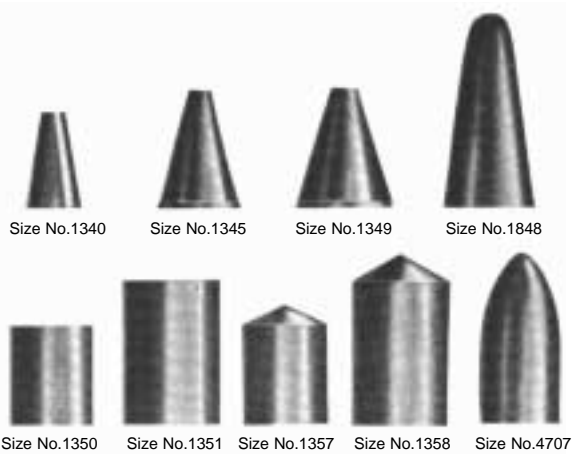

CRATEX CONES

Cratex Cones are the best answer to many difficult deburring, smoothing and polishing problems. They are easily shaped to contour while being used or by using a Cratex conventional dressing tool. They are ideal for cleaning and polishing grooves, ball corners, flares, angles and other hard to reach surfaces as well as for use on molds, dies, castings, combustion chambers and ports, stainless steel tanks, shafts, turbine blades, and many others.

Dimensions in inches

Shape	Length	Diameter	Arbor Hole	Part No.
Tapered	1	5/8 to 1/4	1/4	1340
Tapered	1-1/4	7/8 to 1/4	1/4	1345
Tapered	1-1/4	1 to 1/4	1/4	1349
Tapered	2	1 to 1/2	1/4	1848
Cylinder	1	7/8	1/4	1350
Cylinder	1-1/2	1	1/4	1351
Pointed	1-1/4	7/8	1/4	1357
Pointed	1-3/4	1	1/4	1358
Bullet	1-3/4	7/8	1/4	4707

CRATEX Cone Mandrel — Part No. 1341 (actual size)



Cratex Rubberized Abrasives Cones are designed to fit Cratex Cone Mandrel No. 1341, 1/4" Shank. Maximum Safe Speed 20,000 Revolutions Per Minute with 1/2" overhang or less (exposed mandrel length). For each additional 1/4" of overhang the Maximum Safe Speed is decreased by at least 20%.

Maximum Safe Speed is 20,000 Revolutions Per Minute. Best results are usually obtained at 30% to 80% of Maximum Safe Speed. Use a light work pressure.

CRATEX BLOCKS AND STICKS

Possessing the same superior qualities as other Cratex products, Cratex Blocks and Sticks are excellent hand tools for cleaning and polishing metal surfaces, for breaking edges, smoothing away high spots, removing rust, heat marks, tarnish and stains. Designed for either manual or mechanical operation, they can be mounted in tool holding fixtures, chucks, or cradles. Use them for polishing shafts...damaskeening...cleaning and dressing diamond wheels...polishing rotating cylindrical parts, cleaning calibrations and reference points, and for removing feather edges and touching up cutting tools, dies, chisels and other sharp edged tools.



Dimensions in inches

Length	Cross Section	Part No.
6	SQUARE ■	
	1/4 x 1/4	6202
	1/2 x 1/2	6404
	3/4 x 3/4	6606
	1 x 1	6808
3	OBLONG ■■■	
	1 x 1/4	3802
4	2 x 3/8	4163
6	1 x 1/8	6801
	1 x 1/4	6802
	1 x 3/8	6803
	2 x 1/4	6162
	2 x 1	6168
8	1 x 1/2	8804
6	ROUND ●	
	3/16	036
	1/4	046
	5/16	056
	3/8	066
	1/2	086
	5/8	0106
	3/4	0126
	7/8	0146
	1	0166

CRATEX STRAIGHT WHEELS — LARGE SIZE

Dimensions in inches

Diameter	Thickness	Arbor Hole	Part No.
1-1/2	1/8	1/8	152
	3/16	1/4	153
	1/4	1/4	154
	3/8	1/4	156
	1/2	1/4	158
2	1/8	1/4	202
	3/16	1/4	203
	1/4	1/4	204
	3/8	1/4	206
	1/2	1/4	208
2-1/2	1/4	1/4	254
	3/8	1/4	256
	1/2	1/4	258
3	1/8	1/4	302
	1/4	1/4	304
	3/8	1/4	306
	1/2	1/4	308
	3/4	1/2	312
	1	1/2	316
4	1/8	1/2	402
	1/4	1/2	404
	3/8	1/2	406
	1/2	1/2	408
	3/4	1/2	412
	1	1/2	416
5	1/8	1/2	502
	1/4	1/2	504
	3/8	1/2	506
	1/2	1/2	508
	3/4	1/2	512
	1	1/2	516
6	1/8	1/2	602
	1/4	1/2	604
	3/8	1/2	606
	1/2	1/2	608
	5/8	1/2	610
	3/4	1/2	612
	1	1/2	616
	1-1/2	1/2	624
7	1/4	1/2	704
	3/8	1/2	706
	1/2	1/2	708
	3/4	1/2	712
	1	1/2	716
8	1/4	1/2	804
	3/8	1/2	806
	1/2	1/2	808
	5/8	1/2	810
	3/4	1/2	812
	1	1/2	816
	1-1/2	5/8	824
10	1/4	5/8	1004
	3/8	5/8	1006
	1/2	5/8	1008
	5/8	5/8	1010
	3/4	3/4	1012
	1	3/4	1016
	1-1/4	3/4	1020

Cratex Large Wheels have found wide application for removing rust, heat marks, tarnish, excess solder, scratches, corrosion...blending in and polishing welded seams after rough grinding...polishing bearing surfaces and raceways...removing burrs and breaking edges...smoothing and polishing castings and punched or sheared pieces...wet sanding of gem stones...trimming plastic articles...smoothing glass edges...cleaning before welding or soldering...and for countless other deburring, smoothing, and polishing operations.



- Hole sizes shown are the minimum diameter recommended for the various wheel sizes listed and wheels will be supplied this way unless larger holes are specified on your order. Wheels with larger holes can be ordered at the same price, providing hole diameter is a multiple of 1/8" and does not exceed 1-1/4". For other hole sizes, request pricing.
- MAXIMUM SAFE SPEEDS** in Revolutions Per Minute: 1-1/2" dia.-15,000; 2"-10,500; 2-1/2"-8,300; 3"-7,000; 4"-5,250; 5"-4,200; 6"-3,600; 7"-3,000; 8"-2,600; 10"-2,100. These speeds are based on 5,500 Surface Feet Per Minute. Best results are usually obtained at 30% to 80% of Maximum Safe Speed. Use light work pressure.

CRATEX Wheel Mandrel — Part No. 1342 (actual size)



Cratex Wheel Mandrel No. 1342 has a 1/4" shank and is designed for 1/4" center hole wheels up to 3" diameter by 1/2" thick or less. The maximum safe speeds listed above are for 1/2" overhang or less (exposed mandrel length). For each additional 1/4" of overhang the maximum safe speed is decreased by at least 20%.

CRATEX DRESSING BLOCK — Part No. 6404-2148

The Cratex Dressing Block is ideally suited for truing, dressing, and shaping all Cratex Rubberized Abrasive Wheels. The shape is easy to handle, and the combination of fast cutting abrasive with a hardened bond provides an easy to use, efficient, and long lasting dresser that will enable you to achieve optimum performance from all your Cratex Rubberized Abrasive Wheels.

Size: 6" x 1/2" x 1/2"

CRATEX KITS *(Not available in Hard-Bond)*



CRATEX COMBINATION KIT NO. 226

Kit No. 226 is a comprehensive introductory assortment of Cratex Blocks and Sticks, Cones, 2" Wheels and 1/4" shank mandrels. The Kit contains items which are widely used in a broad range of industrial and metalcraft applications involving light deburring, smoothing, cleaning, and polishing.

Contents of Kit 226

4 Oblong Blocks No. 6803 — 6" x 1" x 3/8"
4 Round Sticks No. 086 — 6" x 1/2" dia.
4 Tapered Cones No. 1345 — 1-1/4" length, tapered 7/8" to 1/4"
4 Cylinder Cones No. 1350 — 1" length x 7/8" dia.
4 Straight Wheels No. 204 — 2" dia. x 1/4" thick x 1/4" hole
1 Cone Mandrel No. 1341 — 1/4" Shank
1 Wheel Mandrel No. 1342 — 1/4" Shank
Equally assorted in the four Cratex Grit Textures — C,M,F,XF

CRATEX CONE TEST KIT NO. 227

Kit No. 227 contains 18 Cratex Cones plus two No. 1341 Cone Mandrels. There are 9 Cratex coarse grit Cones and 9 fine grit Cones in the Kit. Ideal for smoothing, cleaning and polishing grooves, ball corners, flares, angles, holes and other hard to reach surfaces.

Contents of Kit 227

2 Tapered Cones No. 1340 — 1" length, tapered 5/8" to 1/4"
2 Tapered Cones No. 1345 — 1-1/4" length, tapered 7/8" to 1/4"
2 Tapered Cones No. 1349 — 1-1/4" length, tapered 1" to 1/4"
2 Tapered Cones No. 1848 — 2" length, tapered 1" to 1/2"
2 Cylinder Cones No. 1350 — 1" length x 7/8" dia.
2 Cylinder Cones No. 1351 — 1-1/2" length x 1" dia.
2 Pointed Cones No. 1357 — 1-1/4" length x 7/8" dia.
2 Pointed Cones No. 1358 — 1-3/4" length x 1" dia.
2 Bullet Cones No. 4707 — 1-3/4" length x 7/8" dia.
2 Cone Mandrels No. 1341 — 1/4" Shank
Equally divided between C-Coarse and F-Fine Grit Textures



CRATEX BLOCK AND STICK TEST KIT NO. 228

Kit No. 228 contains 16 of the most popular Cratex Blocks and Sticks. Excellent for cleaning, deburring and polishing metal surfaces, for breaking edges, smoothing away high spots, removing rust, heat marks, tarnish and stain.

Contents of Kit 228

4 Oblong Blocks No.6803 — 6" x 1" x 3/8"
4 Square Blocks No.6404 — 6" x 1/2" x 1/2"
4 Round Sticks No.066 — 6" x 3/8" dia.
4 Round Sticks No.086 — 6" x 1/2" dia.
Equally assorted in the four Cratex Grit Textures — C,M,F,XF

CRATEX POLISHING KIT NO. 232

This Kit contains a comprehensive assortment of Cratex items especially selected for automotive, aerospace, marine and general industrial applications - 22 of the most popular Cratex Polishing Wheels, Cones and Blocks in all four grit textures plus two mandrels.

Contents of Kit 232

8 Tapered Cones No. 1340 — 1" length, tapered 5/8" to 1/4"
4 Pointed Cones No. 1357 — 1-1/4" length x 7/8" dia.
4 Pointed Cones No. 1358 — 1-3/4" length x 1" dia.
3 Oblong Blocks No.6803 — 6" x 1" x 3/8"
3 Straight Wheels No.204 — 2" dia. x 1/4" thick x 1/4" hole
1 Cone Mandrel No. 1341 — 1/4" Shank
1 Wheel Mandrel No. 1342 — 1/4" Shank



CRATEX SMALL WHEEL AND MANDREL KIT NO. 707

Kit No. 707 contains 2 of each of the most popular Cratex Small Wheels. A total of 44 Wheels and 2 Mandrels are packed in a four compartment plastic box for easy selection. Cratex Small Wheels are widely used by the hobbyist as well as having a multitude of industrial applications.

Contents of Kit 707

8 Straight Wheels No.86 — 1" dia. x 3/16" thick
8 Straight Wheels No.80 — 1" dia. x 1/8" thick
8 Straight Wheels No.74 — 7/8" dia. x 1/8" thick
8 Straight Wheels No.54 — 5/8" dia. x 1/8" thick
4 Tapered Edge Wheels No. 5 — 1" dia. x 1/8" thick
2 Wheel Mandrels No. 3 — 1/8" shank
Equally assorted in four Cratex Grit Textures — C,M,F,XF



CRATEX POINT AND MANDREL KIT NO. 767

Kit No.767 contains two of each of the four grit textures of the five most popular Cratex Small Points. A total of 40 Points plus two each of the No. 4 and No. 6 Mandrels. Packaged in a four compartment plastic box by grit textures C,M,F,& XF for easy selection.

Contents of Kit 767

8 Bullet Points No.8 — 1" length x 9/32" dia.
 8 Bullet Points No.10 — 5/8" length x 3/8" dia.
 8 Bullet Points No.11 — 1" length x 3/8" dia.
 8 Tapered Points No.14 — 7/8" length x 5/8" to 1/8" dia.
 8 Bullet Points No.15 — 7/8" length x 1/2" dia.
 2 Point Mandrels No.4 — 1/8" shank
 2 Point Mandrels No.6 — 1/8" shank
 Equally assorted in four Cratex Grit Textures — C,M,F,XF

CRATEX INTRODUCTORY KIT NO. 777

Kit No. 777 contains 80 Wheels and Points plus four Mandrels. Packaged in a four compartment plastic box by grit textures C,M,F,& XF for easy selection. Ideal for use in a wide range of polishing, smoothing and deburring applications.

Contents of Kit 777

8 Tapered Edge Wheels No.2 — 5/8" dia.
 16 Straight Wheels No.74 — 7/8" dia. x 1/8" thick
 8 Straight Wheels No.86 — 1" dia. x 3/16" thick
 16 Cylinder Points No.6 — 7/8" length x 1/4" dia.
 16 Bullet Points No.8 — 1" length x 9/32" dia.
 8 Bullet Points No.10 — 5/8" length x 3/8" dia.
 2 Wheel Mandrels No.3 — 1/8" shank
 2 Point Mandrels No.4 — 1/8" shank
 Equally assorted in four Cratex Grit Textures — C,M,F,XF



CRATEX POINT TEST KIT NO. 778

Kit No. 778 contains two each of all eight Cratex Point shapes equally assorted in four grit textures - a total of 64 Points plus two No.4 and two No.6 Point Mandrels. Ideal for deburring, smoothing and polishing hard to reach surfaces.

Contents of Kit 778

8 Cylinder Points No.4 — 1/2" length x 1/4" dia.
 8 Cylinder Points No.6 — 7/8" length x 1/4" dia.
 8 Bullet Points No.8 — 1" length x 9/32" dia.
 8 Bullet Points No.10 — 5/8" length x 3/8" dia.
 8 Bullet Points No.11 — 1" length x 3/8" dia.
 8 Tapered Points No.12 — 7/8" length x 3/8" to 5/16" dia.
 8 Tapered Points No.14 — 7/8" length x 5/8" to 1/8" dia.
 8 Bullet Points No.15 — 7/8" length x 1/2" dia.
 2 Point Mandrels No.4 — 1/8" shank
 2 Point Mandrels No.6 — 1/8" shank
 Equally assorted in four Cratex Grit Textures — C,M,F,XF

CRATEX SANDING KIT NO. 779

The contents of Cratex Sanding Kit No. 779 have been carefully selected after consultation with experienced lapidariests, jewelry makers, and metal smiths. The 45 Cratex Wheels and Points and 4 Cratex Mandrels are neatly packaged in a four compartment plastic box for easy selection.

Contents of Kit 779

21 Straight Wheels No.74 — 7/8" dia. x 1/8" thick
 12 Wheels No.53 — 5/8" dia. x 3/32" thick
 9 Tapered Edge Wheels No.2 — 5/8" dia.
 3 Bullet Points No.8 — 1" length x 9/32" dia.
 3 Wheel Mandrels No.3 — 1/8" shank
 1 Point Mandrel No.4 — 1/8" shank



CRATEX TOOL ROOM ASSORTMENT NO. 796

Developed to meet the demands of industry for a working assortment of Cratex Rubberized Abrasives for general shop and tool room requirements. This comprehensive assortment comes in a compartmented dispensing tray — takes little space (10-1/2" x 15") and makes items in textures and sizes immediately available without workers losing time. The assortment No.796 is also widely used as a sales display by Cratex Distributors.

Contents of Tool Room Assortment 796

200 Tapered Edge Wheels No.2 — 5/8" dia.
 200 Wheels No.53 — 5/8" dia. x 3/32" thick
 100 Straight Wheels No.74 — 7/8" dia. x 1/8" thick
 100 Cylinder Points No.6 — 7/8" length x 1/4" dia.
 100 Bullet Points No.8 — 1" length x 9/32" dia.
 24 Point Mandrels No.1 — 3/32" shank
 24 Wheel Mandrels No.2 — 3/32" shank
 24 Wheel Mandrels No.3 — 1/8" shank
 24 Point Mandrel No.4 — 1/8" shank
 Equally assorted in four Cratex Grit Textures — C,M,F,XF



CRATEX ROTARY HANDPIECE MODEL 800

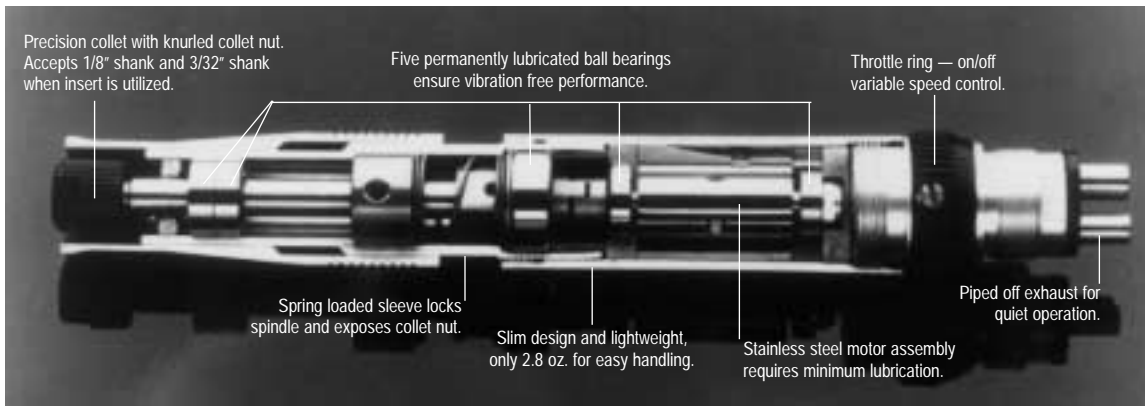

The Cratex Rotary Handpiece is a variable speed precision air tool manufactured to the highest quality standards. Its high torque, lightweight and rugged stainless steel construction make the handpiece ideal for use in a wide variety of precision grinding, finishing and polishing operations. Built into the handpiece is a quick change collet that accepts 1/8 inch and 3/32 inch diameter shanks and mandrels.

For more information ask for a Cratex Rotary Handpiece brochure and price list.

WARNING!
GRINDING WHEELS
IMPROPERLY USED
ARE DANGEROUS.

Caution: comply with American National Standards Institute, Inc. (ANSI) B7.1 Safety requirements for the use, care and protection of abrasive wheels. See page two of this catalog for availability.



OPERATING RULES AND METHODS

Cratex Rubberized Abrasives are carefully manufactured, tested and inspected. Nevertheless, as with all abrasive products, they must be used properly and in accordance with established safety codes. ANSI B7.1, as mentioned on the second page of this catalog, is mandatory reading for all grinding wheel users!

MOUNTING: The area of greatest stress in abrasive wheels is at the center hole. Wheels should therefore be mounted on spindles or arbors of correct diameter (nominal diameter plus zero minus .002 inches). Avoid forcing the wheel onto the spindle. Proper fit, neither too tight or too loose, is essential.

Cratex Wheels shall be mounted only on straight spindles (not tapered) and shall be supported by standard abrasive wheel flanges of equal size covering at least 30% of the wheel diameter. The back flange should be keyed or secured to the shaft (except when mounted on a mandrel) and the outside flange nut should be tightened only enough to keep the wheel from slipping while it is in use. Several Cratex Wheels can be mounted in series for additional width, providing the mounting spindle is large enough to support the extra weight.

PROTECTIVE GUARDS AND SHIELDS: When operating an abrasive wheel, the operator should be properly shielded. The operator as well as any other personnel in the work area should wear safety goggles and face shields.

WHEEL DRESSING: The same dressing and truing tools and methods are used on Cratex products as are used on conventional grinding wheels. Cratex Dressing Blocks are ideal as are all types of manual or mechanical dressers and

diamond truing tools. Truing achieves a concentric geometry between the periphery of the wheel and the spindle on which the wheel is mounted. Dressing is a cleaning operation. It clears the wheel face and exposes fresh, sharp-cutting abrasive grains. Procedure: The dresser or turning tool should be supported on a work-rest (set not more than 1/8 inch away from the wheel face) and held at a slight (5 to 20 degree) angle to the wheel face. Light cuts should then be taken in a straight line across the high points of the wheel until the face is smooth and even. The wheel must not be run at full speed until any signs of imbalance have been removed.

After the wheel has been trued or shaped it should be permitted to turn at full speed (not to exceed maximum safe speed) for one minute or more before work is applied. During this time the operator should stand to one side, away from the wheel.

Stocked and distributed by: